

Hebel[®]

for future living



HEB - 2006
Environmentally Innovative Products

The way to a perfect finish

High Performance Coating Systems

Designed for Future Living



HEBLA207 December 2007



Looking Smooth

Hebel® coatings systems have been specifically formulated to suit Hebel® panels and blocks, engineered to accommodate the thermal expansion and contraction and physical characteristics that are unique to AAC (autoclaved aerated concrete).

Easy to work with, Hebel® coatings are designed to help you achieve the perfect finish to any Hebel® project, including the highly sought after smooth, Monolithic look.

CSR™ Hebel® has worked closely with Dulux® AcraTex® to develop a total system for each market segment - all tested in the market place and strongly supported by both companies.

Given the variability of some coatings – not all are what they claim to be – customers can be confident that when they choose Hebel® coatings they have been correctly formulated to a consistent recipe.

Dulux® is the most recognized brand of paint and coating systems in Australia. They manufacture and distribute a wide range of quality products, with over 230 outlets around Australia.

The CSR™ Hebel® and Dulux® AcraTex® relationship is an industry first alliance, delivering true integration of substrate and coatings to ensure lasting performance.

Hebel® SkimCoat and Hebel® HighBuild™ have been formulated with a special acrylic polymer and combined with washed, graded silica sand, cement and selected additives to enhance the application and workability of the mix, ensuring a consistent finish.

Hebel® PowerBase™ and PowerFinish™ is a unique, all acrylic system that uses no cement.

The addition of acrylic polymers provides Hebel® coating systems with many advantages over traditional cement based renders:

- Increased flexibility.
- Improved adhesion to Hebel® substrate.
- Superior resistance to shrinkage.
- Faster curing.
- Improved crack joint resistance.
- Contributes to thermal properties of Hebel® systems.

CSR™ Hebel® now has three coating systems to cover all applications:

Hebel® PowerBase™ and PowerFinish™

- Revolutionary, all acrylic flexible system for Hebel® panels installed true and flush.
- Two coat process; fast and efficient to apply.
- Watertight, long lasting, low maintenance sand texture appearance.
- Colour integrated throughout; minimizes possibility of minor chips or damage showing; no need for further paint trade.
- No cement; won't harden or go brittle with age.

Hebel® SkimCoat (base for approved acrylic texture system)

- Polymer and fibre reinforced skim coat render for Hebel® panels installed true and flush or ≤1mm tolerance.
- Fast to apply; provides a semi-sealed surface (after overnight cure) ready for approved Acrylic Texture and Finish Coats (which provide the colour).
- Primer often not required.
- Won't crack or go brittle like standard sand cement renders.

Hebel® HighBuild™ (base for approved acrylic texture system)

- Polymer enhanced render for Hebel® blocks and panels installed with tolerances ≤ 3mm.
- Levels irregularities; provides a high build coat.
- Can be float or sponge finished ready for approved Acrylic Texture and Finish Coats (which provide the colour).
- Won't crack or go brittle like standard sand cement renders.

Inside you will find information on the correct coating system to use for each segment, plus detailed preparation and application guides.



The Right Coating for the Job

CSR™ Hebel® needs coating systems that are specifically designed for the characteristics of AAC (Autoclaved Aerated Concrete). Standard coating systems consist of a base levelling coat, texture coat* and elastomeric membrane.

The BASE LEVELLING component of the system must provide:

- A platform to support the specified standard of finish (aesthetic).
- Long-term durability and compatibility with the specific substrate technical requirements.
- FULL composite system warranty from relevant components supplier(s).

A flexible ACRYLIC TEXTURE body coat is recommended to provide:

- Increased system crack-bridging performance.
- Consistency of aesthetic finish.

An ELASTOMERIC MEMBRANE finishing coat is recommended to provide:

- Ultimate durability and weather protection.
- Long term crack-bridging and barrier performance.
- Self cleaning properties.
- Colour consistency, durability and ease of touch-up.

*Except the PowerBase™/PowerFinish™ system

Table 1. Coating Systems Comparison

Recommended and Endorsed by CSR™ Hebel® and Dulux® AcraTex®				Not Recommended	
BASE LEVELLING SYSTEM	CSR™ Hebel® HighBuild™ Polymer enhanced render	CSR™ Hebel® SkimCoat Polymer & fibre AAC engineered skim coat.	CSR™ Hebel® PowerBase™ & PowerFinish™ 100% polymer integrated Base and Finish system engineered for Hebel® AAC	Site mixed Sand & Cement Render	Premixed (bagged) Sand & Cement Render
	Designed for 4-8mm applications to Hebel® Block and Panel in accordance with segment recommendations.	Designed for 2-4mm applications to Hebel® PowerPanel™ installed to ≤1mm tolerances.	Designed for 2-3mm & 1-2mm application to Hebel® PowerPanel™ installed flush and true.	Variable formulation and finish.	Designed for cement and clay substrates.
	Suitable for CSR™ Hebel® Block and Panel requiring high build levelling (≤ 3mm tolerances).	Polymer/Fibre engineered for optimal thinbuild flexural strength.	TOTAL ACRYLIC system providing maximum flexibility. 2 coat integrated system. Fastest system install window.	Prone to cracking. Potential for AAC substrate damage.	Prone to cracking. Potential for AAC substrate damage.
COATING SYSTEM REQUIREMENT	PRIMER Consolidating masonry primer.	PRIMER Generally not required. Application of a consolidating masonry primer will aid application of subsequent Texture Coatings systems by reducing suction and extending working time.	Hebel® POWERFINISH™ Hebel® PowerBase™ & PowerFinish™ provides the Levelling, Texture and Finishing layers in a 2 coat full Acrylic system including colour. The finish provides a weatherproof system. Shieldcoat application is recommended in coastal locations for maximum resistance to dirt pick up.	N/A	N/A
	ACRYLIC TEXTURE Complying with AS4548.4 Min Dry Film Thickness: 1.2mm Min Polymer content (dry): 9% Recommended to produce consistency of finish - refer specific market segment recommendations for information relating to CSR™ Hebel® HighBuild™ systems with Elastomeric Shield coat (without Acrylic Texture). ELASTOMERIC MEMBRANE (refer Table 2) finish coat complying with AS4548.1 Min Dry Film Thickness 150 micron - refer also to market segment recommendations.				
Conventional exterior low build paint systems are strictly not recommended					

The following table details performance requirements of the finishing coat, defined as a High Build Elastomeric Membrane (as recommended by CSR™ Hebel® over approved Acrylic Texture or sponge finished Hebel® HighBuild™ systems, in accordance with relevant market segment recommendations outlined in this brochure).

Table 2. Finish Coat - Minimum Requirements

HighBuild™, Acrylic, Elastomeric coating system independently tested to AS 4548:5 and performance accepted by specifier as being suitable for the proposed application			
Attribute	General Description	Minimum Performance Specification	
Durability/Resistance to Weathering	UV resistant, non yellowing, proven exterior durability	AS4548.1.1	48 months exposure
Crack-bridging (Elasticity/Tensile Strength)	Must be capable of bridging hairline and fine cracks	AS4548.5 Appendix F	0.5mm (minimum)
Water Transmission Resistance (weather proofing)	Must prevent water (weather) ingress	AS4548.5 Appendix B	Less than 10g/24hr/m ² /kPa
Water Vapour Permeability (breathability)	Must allow escape of moisture vapour whilst maintaining a water resistant (weather) barrier	AS4548.5 Appendix C	Sd less than or equal to 2m
Minimum recommended Dry Film Thickness	Relevant to Specified System (refer market segment guide recommendations)	In system with approved Acrylic Texture	150 micron
		In system without approved Acrylic Texture (Hebel® HighBuild™ sponge finish aesthetics)	250 micron

Detached Housing & Low Rise Multi-Residential

CSR™ Hebel® has developed building systems for all aspects of Detached Housing and Low Rise Multi-Residential construction.

The following table details CSR™ Hebel® recommendations for Coating System options for Low Rise and Detached Residential construction to deliver a durable, monolithic appearance.

CSR™ Hebel® and Dulux® AcraTex® have developed coating systems designed specifically for the CSR™ Hebel® AAC substrate and warrant these systems for 7 years. Performance requirements for alternate system options are provided. In such circumstances, the project specifier must satisfy themselves that systems are engineered and suitable for relevant project requirements.

CSR™ Hebel® advises:

- General purpose, site or pre-bagged sand and cement renders are not recommended by CSR™ Hebel®, owing to potential variability and unsuitability of formulation for Autoclaved Aerated Concrete.
- Conventional exterior low build paint systems are not recommended, as their ability to accommodate normal expansion and contraction in order to maintain a crack free protective layer is not assured.

Table 3. Coating systems for Detached Housing and Low Rise Multi-Residential

CSR™ Hebel® Product	Finish Style	Surface Alignment	Base Render or Levelling Coat	Primer		Acrylic Texture Body Coat		Finish Coats		Comment
				Product Description & Performance Guide	Dulux® AcraTex® Specification	Product Description & Performance Guide	Dulux® AcraTex® Specification	Product Description & Performance Guide	Dulux® AcraTex® Specification	
PowerPanel™	Uniform Sand Texture profile	True & Flush	CSR™ Hebel® PowerBase™	Self priming Sand and spot prime excessive adhesive extending across joints with AcraPrime 501/1		Engineered for CSR™ Hebel®. No AS STD type or equivalent	PowerFinish™		Optional	Elastomeric Membrane recommended for improved resistance to dirt pick up and coastal environments.
PowerPanel™	Uniform Sand Texture profile	≤1mm	CSR™ Hebel® SkimCoat (Render)	Relevant to Coating supplier recommendations	Self priming	1-2mm Acrylic Texture Trowel applied Type: AS4548.4 Polymer content (dry): 9% min.	Tuscany or Coventry Coarse	Elastomeric Membrane Type: AS4548.1 Min. DFT: 150 micron	AcraShield Matt or Elastomeric 201	2nd coat Elastomeric Membrane recommended dependant on project complexity eg. unbroken broadwall, scaffolding or cutting in detail and coastal areas.
PowerPanel™	Uniform Sand Texture profile	≤3mm	CSR™ Hebel® HighBuild™ (Render)	Relevant to Coating supplier recommendations	AcraPrime 501/1	OPTION 1: 1-2mm Acrylic Texture Trowel applied Type: AS4548.4 Polymer content (dry): 9% min.	Tuscany or Coventry Coarse	Elastomeric Membrane Type: AS4548.1 Min. DFT: 150 micron	AcraShield Matt or Elastomeric 201	2nd coat Elastomeric Membrane recommended dependant on project complexity eg. unbroken broadwall, scaffolding or cutting in detail and coastal areas.
						OPTION 2: Dependant on specifier approval: Sponge finishing of Hebel® HighBuild™ to a project approved standard; plus Elastomeric Membrane finishing system.		Elastomeric Membrane Type: AS4548.1 Min. DFT: 250 micron	Elastomeric 201	CSR™ Hebel® recommends the installation of 1-2mm Acrylic Texture Coat over the render base coat providing improved consistency of finish, system flexibility and durability.
Block	Uniform Sand Texture profile	≤3mm	CSR™ Hebel® HighBuild™ (Render)	Relevant to coatings supplier recommendations	AcraPrime 501/1	OPTION 1: 1-2mm Acrylic Texture Trowel applied Type: AS4548.4 Polymer content (dry): 9% min.	Tuscany or Coventry Coarse	Elastomeric Membrane Type: AS4548.1 Min DFT: 150 micron	AcraShield Matt or Elastomeric 201	2nd coat Elastomeric Membrane recommended dependant on project complexity eg. unbroken broadwall, scaffolding or cutting in detail and coastal areas.
						OPTION 2: Dependant on specifier approval: Sponge finishing of Hebel® HighBuild™ to a project approved standard; plus Elastomeric Membrane finishing system.		Elastomeric Membrane Type: AS4548.1 Min. DFT: 250 micron	Elastomeric 201	CSR™ Hebel® recommends the installation of 1-2mm Acrylic Texture Coat over the render base coat providing improved consistency of finish, system flexibility and durability.

High Rise Multi-Residential

CSR™ Hebel® is used extensively in High-Rise Multi-Residential projects; using a tough and durable coating system is paramount to achieving a long lasting result.

Large structures of this nature often have more construction variances (eg movement, tolerance, deflection) and an increased cost of rectification if inferior systems are used.

Broad wall areas are highly visible and with the sun reflecting on them this can highlight defective surfaces. Panels should be inspected before coating to ensure the correct system is specified.

CSR™ Hebel® and Dulux® AcraTex® recommend the coating system using Hebel® HighBuild™ shown in Table 4 below. When installed through accredited CSR™ Hebel® and Dulux® installers, a full system warranty is achievable.



Table 4. Coating system for High Rise Multi-Residential

CSR™ Hebel® Product	Build Style	Finish Style	Surface Alignment	Base Render or Levelling Coat	Primer	Acrylic Texture Body Coat	Finish Coat	Comment
PowerPanel™	Monolithic	Uniform Sand Texture profile	≤3mm	Hebel® HighBuild™ (Render)	AcraTex® AcraPrime 501/1	AcraTex® Tuscany or Coventry Coarse	AcraTex® AcraShield Matt or Elastomeric 201, 2 coats	Min. 2 coats recommended due to increased complexity of broad wall aesthetics, scaffolding or cutting in detail.

Commercial & Industrial

Commercial and Industrial buildings also require a tough and durable coating system that caters for the nature of larger structures. CSR™ Hebel® again recommend the Monolithic Build Style (using Hebel® HighBuild™) for this segment. If a lower cost system is required, the Express Options may be used, however please ensure any paint finishes comply with the manufacturers requirements (refer to Tables 1 and 2).



Table 5. Coating systems for Commercial & Industrial

CSR™ Hebel® PowerPanel™	Build Style	Finish Style	Surface Alignment	Base Render or Levelling Coat	Primer	Acrylic Texture Body Coat	Finish Coat	Comment
	Monolithic	Uniform Sand Texture profile	≤3mm	Hebel® HighBuild™ (Render)	AcraPrime 501/1	Tuscany or Coventry Coarse	AcraShield Matt or Elastomeric 201 2 coats	Min. 2 coats of finishing membrane recommended due to increased complexity of broad wall aesthetics, scaffolding or cutting in detail.
Express Option 1 Low profile, Roll On Texture Uniform texture, Weather-tight finish	Express V-Joint	Texture roller low profile. Will unify minor panel blemishes	True and Flush	N/A	AcraSilane	AcraSand	AcraSand	AcraSilane primer provides a water transmission barrier at the substrate interface for improved system performance in low build system recommendations.
Express Option 2 High Build Elastomeric coating Weather-tight finish	Express V-Joint	High Build paint finish. Will not hide surface profile	True and Flush	N/A	AcraSilane	AcraShield Matt	AcraShield Matt	AcraSilane primer provides a water transmission barrier at the substrate interface for improved system performance in low build system recommendations.

Do It Yourself (DIY)

Hebel® Handi Blocks and Panels are suitable for many DIY projects, such as bench seating and barbecues, tables, dog kennels, letterboxes, bath, shower and spa hobs. CSR™ Hebel® recommends the use of Hebel® HighBuild™ render as the base levelling coat, followed by an acrylic texture body coat for lasting protection.

Three styles of acrylic texture coating are available from Dulux® – your choice depends on the degree of levelling required and end look you desire. Available from all leading paint and hardware outlets, larger stores have in-store displays of Dulux® texture coat options, with a step by step application guide video entitled “Exploring Exterior Textures”.

Complete the project with two coats of premium exterior acrylic paint as the final coating – available in a wide range of beautiful colours - creating a durable finish that will last for years.

Table 6 outlines the recommended coating options for DIY projects. Refer also to the DIY Application Guide on page 7.



Table 6. Coating Systems for DIY projects - Hebel® Handi

Build/ Finish Style"	Base Render/ Levelling Coat	Prime Coat	Acrylic Texture Body Coat	Finish Coats	Comments
Fine Sand (low build texture)	CSR™ Hebel® HighBuild™ render Usage rate: 10kg/m ² @6mm thick	4 parts DFT to 1 part water	Dulux® Fine Texture (DFT) Usage rate: 3-4m ² /L	Dulux® Weathershield® X10 Usage rate: 12-14m ² /L	Prep: Apply Hebel® HighBuild™ in accordance with product instructions. Allow min 7 days cure before overcoating. Block down (brick or masonry rubbing stone) and wash the surface to remove all loose material and surface contaminants prior to coating. Prime Coat: Recommended to reduce 'suction' on porous surfaces and produce the best level of finish of subsequent coats. Mix 4 parts Dulux® Fine Texture with 1 part water and apply by nap roller in accordance with label instructions. Allow to dry for 4 hours before recoating. Finish Coat: Apply without thinning using a nap roller in accordance with label instructions. Texture Tip: Dulux® Fine Texture is applied thicker than standard paint – do not overspread the material. For best results use a 12mm synthetic lambswool blend roller, delivering the material in strips and not fully emptying the roller out; then even the material out by rolling diagonally. Finish in one direction, 'laying off' with lighter strokes moving across the area applying less pressure on the 'finished side'.
Bagged (Tuscan texture)	CSR™ Hebel® HighBuild™ render Usage rate: 10kg/m ² @6mm thick	4 parts DMT to 1 part water	Dulux® Medium Texture (DMT) Usage rate: 2-3m ² /L	Dulux® Weathershield® X10 Usage rate: 12-14m ² /L	Prep: Apply Hebel® HighBuild™ in accordance with product instructions. Allow min 7 days cure before overcoating. Block down (brick or masonry rubbing stone) and wash the surface to remove all loose material and surface contaminants prior to coating. Prime Coat: Recommended to reduce 'suction' on porous surfaces and produce the best level of finish of subsequent coats. Mix 4 parts Dulux® Medium Texture with 1 part water and apply by nap roller in accordance with label instructions. Allow to dry for 4 hours before recoating. Finish Coat: Apply without thinning using a nap roller in accordance with label instructions. Immediately 'work' the material with a sponge or applying mitt in a random fashion according to the desired level of texture profile required. Texture Tip: Dulux® Medium Texture is applied thicker than standard paint – do not overspread the material. For best results use a 12mm synthetic lambswool blend roller, delivering the material in strips and not fully emptying the roller out. Various finishing tools can then be used to create the desired texture profile ranging from a light relief 'bagging' finish using a fine cell sponge and light sweeping strokes through to a more textured "stucco" finish using a mitt applicator or trowel in a patterning motion.
Monolithic (float render Texture)	CSR™ Hebel® HighBuild™ render Usage rate: 10kg/m ² @6mm thick	4 parts DFT to 1 part water	Dulux® Full Cover Texture (FCT) Usage rate 1m ² /L	Dulux® Weathershield® X10 Usage rate: 12-14m ² /L	Prep: Apply Hebel® HighBuild™ in accordance with product instructions. Allow min 7 days cure before overcoating. Block down (brick or masonry rubbing stone) and wash the surface to remove all loose material and surface contaminants prior to coating. Prime Coat: Recommended to reduce 'suction' on porous surfaces and produce the best level of finish of subsequent coats. Mix 4 parts Dulux® Fine Texture with 1 part water and apply by nap roller in accordance with label instructions. Allow to dry for 4 hours before recoating. Finish Coat: Apply without thinning using a nap roller in accordance with label instructions. Finish with a plastic float to a crisp uniform rendered style finish. Texture Tip: Dulux® Full Cover Texture uses more material than Fine or Medium Texture (up to 1L/m ²) to achieve a 'professionally rendered' appearance. Detailed instructions are included on the label and the application guide booklet on the lid. An application video is also available online at www.dulux.com.au/html/texture or on CD at retail outlets. Two special tools are required – a Dulux® designed Full Cover Roller (essential) and plastic float for finishing.

DIY Application Guide

Base Render/Levelling Coat – CSR™ Hebel® HighBuild™

- Applied using plastering/hawk & trowel method.
- Levels block joints and provides a uniform surface for subsequent acrylic texture options.
- Final finish look is variable dependant on desired style and applying skills.
- Bagged finish achievable with basic application skills.
- Smooth level finish requires sponge finishing render skills.

Hebel® HighBuild™ is designed principally for thick (6mm) applications providing levelling and impact resistance. Where applied in less than 6mm applications, HighBuild™ requires the addition of Dulux® Acrabond (an acrylic cement modifier) to aid proper cure in thin build. Please check the Hebel® HighBuild™ bag labelling for correct mixing advice relevant to applied thickness. Increased acrylic bonding agent is required for thinner applications.

Preparation

For best results, any excess Hebel® Adhesive (when wet) should be struck flush during the block laying process, filling and levelling the joints. When dry, sand the blocks down using a coarse Hebel® sander to minimize step variations from block to block. Broom down all elements to remove surface contaminants. Hebel® HighBuild™ is best applied to slightly damp (not wet) blocks. Dampen the surface prior to application.

Application

Mix Hebel® HighBuild™ according to instructions on the bag. Apply a thick (4-8mm) coat by hawk & trowel (plastering technique) to level the surface. Allow the material to “firm” (partially set, no longer wet or sticky), then float finish with a wooden or plastic float to a uniform level surface. Complete the process using a firm cell sponge for a fine sand finish. A more textured or bagged profile finish can be achieved by modifying your technique according to the style of finish desired.

Tip

Float finishing of render cannot be done when the material is still ‘wet and sticky’. Render is ready for float finishing when it has just firmed, but is still soft enough to allow the surface sand and cement particles to be moved around under a damp rendering sponge float.



Acrylic Texture Body Coat options – Dulux® Fine Texture, Medium Texture, Full Cover Texture

Dulux® Fine Texture

- Applied using painter/nap roller.
- Texture body coat providing the finishing style and colour.
- Provides a light sandy texture that follows the profile of the surface.

Dulux® Medium Texture

- Applied using painter/ nap roller.
- Texture body coat providing the finishing style and increased film build for greater covering ability.
- Provides a bagged style texture finish for a character Tuscan appearance.
- Will cover greater surface imperfections than Fine Texture as it allows for material to be ‘moved and textured’ to create style and mask surface irregularities.

Dulux® Full Cover Texture

- Apply using special texture roller; finish with plastic float.
- Texture body coat providing the finishing style with additional levelling characteristics to level render imperfections.
- Provides a professional rendered appearance without the skills required of a plasterer.
- Traditional sponge finish rendering requires very specific skills. Dulux® Full Cover Texture is applied by special roller then float finished, removing the most difficult step of using a hawk and trowel to deliver material onto the wall.

Finish Coat option – Dulux® Weathershield® X10

- Applied using painter/nap roller.
- Weatherproofing shield coat for maximum system performance.
- Apply two coats in accordance with label instructions.

(Refer also to Table 6)



Fencing



Hebel® PowerFence™ is an extremely versatile fence system that provides an effective noise barrier for residential and commercial applications. Hebel® PowerFence™ is built to last and look good year after year with minimal upkeep and maintenance. The table below outlines the coating options that are recommended for PowerFence™.

Table 7. Coating Systems for Fencing - Hebel® PowerFence™

Build Style	System Components	Skills/Application	Finish Style/Appearance	Coating Thickness	Comment
Monolithic Premium	Hebel® SkimCoat	Plastering/hawk & trowel	<ul style="list-style-type: none"> Uniform sand texture (render style) Various alternate texture styles are available - refer coating manufacturer 	3-5mm	<ul style="list-style-type: none"> Render-texture profile applied by plastering technique. Acrylic texture over fibre reinforced cementitious levelling coat. Good flexibility & excellent weather resistance protection. Colour incorporated throughout the texture body coat. Long term durability enhanced with AcraShield topcoat. Premium impact resistance
	Dulux® AcraTex® Coventry Trowel	Plastering/hawk & trowel			
	Dulux® AcraTex® AcraShield	Painter/nap roller			
Monolithic Economical	Hebel® PowerBase™	Plastering/hawk & trowel	<ul style="list-style-type: none"> Uniform sand texture (render style) 	3-5mm	<ul style="list-style-type: none"> Render-texture profile applied by plastering technique. Full acrylic texture levelling and finishing system. Excellent flexibility & weather resistance protection. Colour incorporated throughout the full system. Good impact resistance.
	Hebel® PowerFinish™	Plastering/hawk & trowel			
Express Joint Premium	Dulux® AcraTex® Contempo Coarse	Painter/nap roller, float or sponge float finishing	<ul style="list-style-type: none"> Fine grain profile following the panel joint profile 	1mm	<ul style="list-style-type: none"> Express joint feature panel appearance, with defined capping detail. 1mm coating thickness, covering the Hebel® surface texture. Applied by painters technique, 'heavily' at 5x conventional paint thickness. Finished by plastic float or sponge to cover the surface texture and follow the express joint profile. Full acrylic finishing system. Good weather resistance. Moderate impact resistance. Colour incorporated through the system.
	Dulux® AcraTex® Contempo Coarse	Painter/nap roller, float or sponge float finishing			
Express Joint Economical	Dulux® AcraTex® AcraSand	Painter/medium black texture roller	<ul style="list-style-type: none"> Following the panel texture and joint profile, producing light texture pattern 	0.5-1mm	<ul style="list-style-type: none"> Express joint economical system, with defined capping detail. Fine 'grit' paint style coating - with light relief texture pattern. Applied by painters technique, at 5x conventional paint thickness. Full acrylic finishing system. Good weather resistance. Colour incorporated through the system. Low impact resistance.
	Dulux® AcraTex® AcraSand	Painter/medium black texture roller			

The edge bevels on Hebel® PowerFence™ panels give definition to the fence surface. If a Monolithic finish is desired, panels must be glued with Hebel® Adhesive to prevent movement and consideration should be given to meshing the joints to prevent hairline cracking.

Surface Preparation

Patching

Fill any chipped and damaged blocks or panels with Hebel® Patch and allow to dry.

Sanding/Levelling

An advantage of Hebel's® walling systems is that surface misalignment in both the block and panel systems can be levelled, using a levelling plane or Hebel® sanding float to achieve a truer flat surface.

Cleaning

Remove all adhesive runs by scraping as soon as possible – the longer the adhesive is left to cure the harder the material becomes, making it more difficult to remove. Remove all free dust, dirt, grease, oils, moss, fungi, mastic compounds and any other foreign matter that could affect the adhesion of the Hebel® coating system. Brush the surface with a stiff bristle broom to remove all loose particles. All surfaces must be clean, sound and free of powdery residue.

Corner Beading

Beading can be used on corners and edges to increase impact/knock resistance and to provide a level edge. The beading used must be external grade and be securely fixed straight and true. These are traditionally fixed using either 25mm coarse thread screws or flat head external grade nails with a small quantity of construction adhesive. Corner beads may need to be rebated into the corners of the Hebel® blocks or panels prior to the application of the coating.

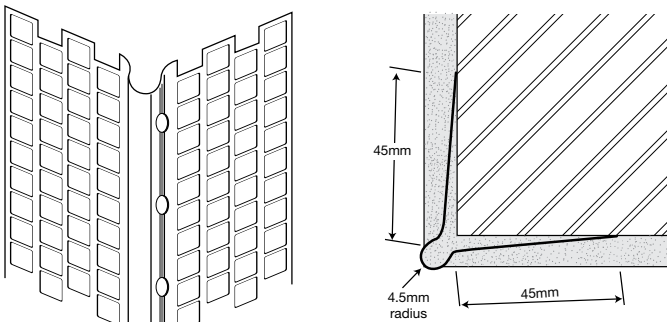

Control Joints

Control joints are best treated before the coating system is applied. The use of a PU – Poly Urethane 'paintable' sealant incorporating backing rod in strict accordance with the manufacturers recommendation for use on AAC should be used in all cases. Select a colour that is complimentary to the final Texture colour. Apply sealant on completion of the panel installation to ensure adequate curing. At application stage, the coatings applicator shall apply a 4-6mm masking tape (matching the joint details) over the cured sealant and once processing of the base coat is completed at the joint, shall immediately remove masking to ensure basecoat does not

bridge the sealant joint. Just prior to the application of the finishing coat, additional masking tape is applied to the recess formed at the joint and removed whilst the finishing coat is still wet. Alternatively no masking tape is applied and the Finishing coat is processed over the joint using a shallow expansion tool. Coating applications over control jointing may crack due to inherent expansion and contraction and subsequent joint defamation.

Pre-wetting

Hebel's® absorbent nature aids adhesion of the coating, however in warmer weather excessive absorption may make the coating difficult to work with. Generally the surface will have to be moistened with water prior to application to reduce surface suction. Alternatively the surface suction can be reduced by the application of a sealer/primer application of a mixture made of one (1) part 100% acrylic bonding agent such as Dulux® AcraTex® 500/4 AcraBond to six (6) parts water applied to the clean, dampened surface.

Climatic Conditions

- Hebel® coating systems must not be applied below 5°C or at elevated temperatures above 30° and in hot windy conditions.
- Hebel® coating systems should be protected from rain and frost for the first 24 hours.
- Application on large areas in full sun should be avoided (and/or the surface should be cooled and tempered with fresh water).
- Always work in shaded areas.
- If wet weather conditions are forecast, application should be stopped to give the coating sufficient time to set.
- Protect the finished work around down pipes, spouts or where water may continually splash or wet the surface.



Hebel® PowerBase™ and PowerFinish™ Application Guide



Purpose

Hebel® PowerBase™ and Hebel® PowerFinish™ is a two coat, total acrylic levelling and finishing system. Dulux® AcraTex® has designed this coating system specifically for CSR™ Hebel® PowerPanel™ which has been installed true and flush. The two coat process delivers maximum project efficiencies, shortening finishing cycle times and providing a traditional sand texture appearance with guaranteed performance.

Hebel® PowerBase™ is a high build levelling and body coat. It provides the core of the texture and finishing system, delivering a 2-3mm flexible build which will accommodate normal building expansion and contraction.

Hebel® PowerFinish™ is a mid build finish and barrier coat (2-3mm). It provides the decorative and protective final layer, delivering a fine grain natural finish whilst maintaining barrier performance through its unique water phobic technology. Colour is incorporated throughout the PowerBase™ and PowerFinish™ layers for maximum durability and scratch resistance.

Equipment

Both Hebel® PowerBase™ and Hebel® PowerFinish™ are applied using the conventional hawk and trowel plastering method. Finish Hebel® PowerBase™ using a polystyrene float or red plastic trowel. Finish Hebel® PowerFinish™ using a red plastic trowel or float.

Mixing

Hebel® PowerBase™ and PowerFinish™ is ready for use as supplied (do not add water or cement). Containers should be stirred before use. Ensure adequate quantities are purchased as a single lot tint to ensure colour uniformity, or cross mix multiple tint lots.

Application Techniques

■ Panel alignment is critical in all cladding systems and specific attention must be given to control of framing and/or panel alignment. The Hebel® PowerBase™ and PowerFinish™ system is only suitable for Hebel® PowerPanel™ installed true and flush.



- CSR™ Hebel® recommends suitable expansion/contraction relief joints (control joints) be installed at natural building weak points if in line with openings (windows/doors), at all horizontal multi-levels and at interfaces of different building construction materials and/or as defined by the Engineer. Hebel® PowerBase™ and PowerFinish™ should not extend across control joints (refer to Surface Preparation on page 9). Ensure that all joints between panels are filled with adequate Hebel® adhesive to allow striking flush of excess glue at panel face and panel to panel and face alignment is true and flat.
- All fixings must be non-corrosive, suitable for the exposure condition and be in accordance with substrate supplier recommendations.
- Hebel® PowerBase™
 - Ensure that all imperfections are filled, flushed, sanded true and level and the surface is clean and free of all contaminants.
 - Sand and spot prime excessive adhesive extending across joints with AcraPrime 501/1.
 - Dampen the surface with clean fresh water to reduce excessive suction and aid coating application. The surface is ready for coating once initial wetness has subsided, leaving it 'dark damp' (within 10-30 minutes on warm days).
 - Apply with hawk & trowel evenly over the panel surface to the thickness of the largest particles. Follow up with a light 'floating' process to level out the product, using a polystyrene float or red plastic trowel.
 - Allow to cure overnight (minimum) before subsequent application of Hebel® PowerFinish™.

■ Hebel® PowerFinish™

- Correctly finished Hebel® PowerBase™ will provide a flush granular surface ready for PowerFinish™ to fill and level. Any surface irregularities or protruding aggregate particles should be scraped flush before commencing the PowerFinish™ application
 - Apply Hebel® PowerFinish™ evenly over the surface, filling the granular base profile. Follow up with a light 'floating' process to level out the product, using a red plastic trowel.
 - Float finishing of PowerFinish™ should fill the profile of the coarser PowerBase™ layer, producing an even finer granular surface appearance.
- Hebel® PowerBase™ and PowerFinish™ droppings should not be re-tempered with water and should be discarded.
- Always terminate the Hebel® PowerBase™ and PowerFinish™ applications above the damp course line. Never bridge the damp course.
- Thoroughly clean all equipment with water.

Table 8. Coverage Rates

Average Thickness	Coats	Approx. Material Usage L/m ²
PowerBase™ 2-3mm	1	2.22L/m ²
PowerFinish™ 1-2mm	1	1.43L/m ²

Finishing / Overcoating

Colour is integrated right throughout the PowerBase™ PowerFinish™ system; hence there is generally no need for overcoating.

A weatherproofing top coat is optional, depending on project requirements. Dulux® AcraTex® AcraShield (shield topcoat) is recommended in coastal environments for maximum resistance to dirt pick up and durability.



Hebel® SkimCoat Application Guide

Purpose

Hebel® SkimCoat is designed for use with Hebel® panel systems. It is fast to apply and suitable for both external and internal surfaces. It can be applied to straight and true panel surfaces at up to 4mm in a single application to produce a high quality even, true surface. It is the ideal substrate for finishing with a high build acrylic texture coating plus an exterior weather proofing coating or a quality acrylic topcoat in interior applications.

Equipment

Hebel® SkimCoat is applied by the conventional hawk and trowel method. A spatula may be useful for smaller areas.

Mixing

The mixing ratio is one 20kg bag of Hebel® SkimCoat to 4.4 to 5.0 litres of clean cold water. The water should first be measured into a 15L clean plastic container and the render slowly incorporated using a power stirrer for a minimum period of 2 minutes, to produce a smooth, lump free consistency.

Application Techniques

- Check the trueness (level) of the work areas prior to commencement of the application. Poorly aligned panels can be corrected using a Hebel® Levelling Plane or Hebel® Sanding Float.
- The application is similar to standard cement render. Apply with a traditional hawk and trowel to achieve a skim coat of about 2mm. As Hebel® SkimCoat is setting, skim the entire surface with a flattened trowel to eliminate application trowel marks, making this a smooth surface for the subsequent acrylic texture coatings.

- An additional application of Hebel® SkimCoat to low areas may be required to achieve a flatter surface; use a straight edge to determine the straightness of the wall.
- Hebel® SkimCoat droppings should not be re-tempered with water and should be discarded.
- Always terminate the Hebel® SkimCoat application above the damp course line. Never bridge the damp course.
- Thoroughly clean all equipment with water.

Table 9. Coverage Rates

Average Thickness	Coats	Approx. Material Usage kg/m ²
2 mm	1	3.6
4 mm	1	7.2

Coverage: 1 mm thickness/m² requires 1.8kg of Hebel® SkimCoat

Working, Drying and Curing times

Hebel® SkimCoat will remain workable for 1-2 hours and will dry in around 4 hours at 25°C and 50% relative humidity depending on the dampness of the substrate. As a general rule however, renders should be kept damp for the first 12 hours to ensure proper hydration of the mixture. If drying is too rapid, hydration will not take place and the render will not develop its full strength and will become crumbly. Note: During hot weather, the wall must be cured for two days after application by re-wetting the render 2 - 3 times per day.

Hebel® SkimCoat should be allowed to cure for a minimum of 7 days prior to the application of subsequent coatings.

Finishing Hebel® SkimCoat

Hebel® SkimCoat is designed as a preparatory basecoat only; a further coat providing a texture profile (and the colour) is then essential.



Hebel® HighBuild™ Application Guide

Purpose

Hebel® HighBuild™ render levels irregularities and produces a high quality even, true surface on both internal and external surfaces. It can be applied at a thickness as low as 4 mm or up to 8 mm (in two successive coats) depending on the coverage and levelling required.

Hebel® HighBuild™ can either be sponge finished or you may choose from an array of acrylic texture finishes, either way a high quality acrylic coating system is required for overall long term protection. Hebel® HighBuild™ render will also add to the acoustic and thermal properties of the Hebel® substrate.

Equipment

Hebel® HighBuild™ can be applied either by a mortar spray/pump or the conventional hawk and trowel method. It is ruled level with straight edges and finished with wood, polystyrene or soft foam finishing floats.

Mixing

The mixing ratio is a 20kg bag of Hebel® HighBuild™ to 3 to 4 litres of clean cold water. The water and bonding agent (if required) should first be measured into a 15L clean plastic container and the render slowly incorporated using a power stirrer for a minimum period of 2 minutes, to produce a smooth, lump free consistency.

Thin bed applications require the addition of a AcraTex® AcraBond (100% acrylic bonding agent) in the following quantities per 20kg bag of Hebel® HighBuild™:

- 2-4 mm thick renders coats: 300ml
- 6mm thick renders coats: 100ml

Application Techniques

- Poorly aligned substrates may require a work screed at the top and bottom of the work area.
- Applications by hawk and trowel should occur in two passes; a tight first pass followed by a second levelling pass wet on wet.
- Screed level and true with a suitable straight edge once surface moisture has stabilized and initially stickiness has passed (usually after 5-10 minutes of render application, dependant on conditions and applied thickness).
- Apply more Hebel® HighBuild™ to any low areas as required.
- Once the surface is true and level use a wooden, polystyrene or soft foam float to produce a uniform surface finish.
- If a three coat paint finish is being applied instead of an acrylic texture profile, the surface must be finished to perfection providing a uniformed textured appearance with no bald spots. Otherwise these areas will show through any paint system, making the wall appearance patchy.

- Hebel® HighBuild™ droppings should not be re-tempered with water and should be discarded.
- Always terminate the Hebel® HighBuild™ application above the damp course line. Never bridge the damp course.
- Thoroughly clean all equipment with water.

Table 10. Coverage Rates

Average Thickness	Coats	Approx. Material Usage kg/m ²
*4 mm	1	7.2
*6 mm	1	10.8
8 mm	1	14.4

Coverage 1 mm thickness/m² requires 1.8 kg of Hebel® HighBuild™

* The use of AcraTex® 500/4 AcraBond is recommended for applications with a coating thickness less than 6mm.

Reinforcing Mesh Installation

The use of alkali-resistant Hebel® glass-fibre mesh is recommended at corners of wall openings (doors and windows) to minimise corner cracking. The mesh should be embedded into the wet first pass of Hebel® HighBuild™.

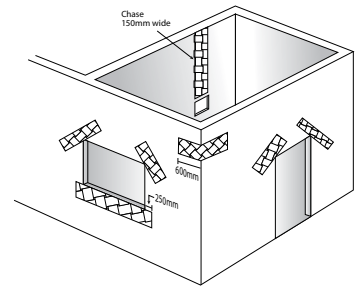

Working, Drying and Curing times

Depending on the applied thickness, Hebel® HighBuild™ will remain workable for 1-2 hours and will dry in around 3-6 hours at 25° C and 50% relative humidity, depending on the dampness of the substrate. As a general rule however, cement renders should be kept damp for the first 12 hours to ensure proper hydration of the mixture. If drying is too rapid, hydration will be greatly reduced, affecting overall render tensile strength and it may become crumbly.

Finishing Hebel® HighBuild™

Hebel® HighBuild™ can be finished using a sponge float to create a fine sand texture; care must be taken to ensure a uniformed textured finish.

Alternatively you can select from an array of acrylic texture profiles that can be applied over the render to upgrade the overall coating performance (and provide the colour).

The Perfect Finish

Finish Coats

Hebel® HighBuild™ has the design flexibility to be either sponge finished or have an acrylic texture coating profile applied.

Hebel® SkimCoat always requires a texture finish. For exterior applications a texture coating system is recommended.

Finishing coats are usually applied after 7 days having ensured the base coating has dried out and proven to be fault free. Regardless of which selection, both options (HighBuild™ and SkimCoat) require the protection of a weather proofing shield coat that is designed to withstand the elements of our environment. The minimum performance characteristics for the shield or top coating are:

1. Water vapour permeability must be S_d less than or equal to 2m vapour transmission.
 2. Weatherproofing performance must meet the criteria of no more than 10g/24hr/m²/kPa of Water Transmission.
- Check independent test results from the coating supplier prior to use
 - Use products such as *Dulux® AcraTex® Texture Systems incorporating 955 AcraShield shield coat

Dulux® Colour is integrated right through Hebel® PowerBase™ and PowerFinish™ for maximum durability. Select from the exterior Dulux® colour range, from pastel through to most deep and ultra



deep colours for broadwall and feature elements. Where extra bright or specialty coloured base selections are made for project elements, these can be top coated with AcraShield top coat to meet project requirements. Hebel® PowerBase™ and PowerFinish™ are available through Dulux® Trade Centres. For project colour samples contact your CSR™ or Dulux® representative.

Internally, Hebel® Coatings add to the impact resistance, acoustic and thermal properties of the Hebel® substrate. Unlike the exterior environment the interior has a set of unique requirements; these include scuff resistance and washability. Top coating is essential to provide protection and lasting good looks. To maximise long term performance use a high quality washable acrylic top coat such as **Dulux® Wash and Wear 101 or similar.

Table 11. Coating sequence

Coating Sequence	Product purpose	Hebel® Block		Hebel® Panel		
		Acrylic Texture (tinted)	Sponge Finish	Acrylic Texture (tinted)	Sponge Finish	PowerBase™/ PowerFinish™
Preparation Coat	Used as a preparation coat to level surface providing an even true surface.	Hebel® HighBuild™ Render 4-8mm	Hebel® HighBuild™ Render 4-6mm	Hebel® SkimCoat Render 2-4mm	Hebel® HighBuild™ Render 4-6mm	Hebel® PowerBase™ (tinted) 2-3mm
Sponge Finish	Finished with a sponge float to create a sponge fine sandy appearance.		Hebel® HighBuild™ Render 4-6mm (sponge finished)		Hebel® HighBuild™ Render 4-6mm (sponge finished)	
Primer	Used to unify the surface porosity of the Hebel® Render, plus aiding in inter-coat adhesion, for following coats.	Acrylic sealer primer	Acrylic sealer primer	Acrylic sealer primer	Acrylic sealer primer	
Acrylic Texture	Provides the flexibility to choose from a variety of different texture profiles. Eliminating shrinkage & micro cracks.	Acrylic texture (tinted)		Acrylic texture (tinted)		
Finish Coats						Hebel® PowerFinish™ (tinted) 1-2mm
EXTERIOR 1st Top coat	Protection from the elements.	*Acrylic high build shield coating	*Acrylic high build shield coating	*Acrylic high build shield coating	*Acrylic high build shield coating	Shield coating recommended in coastal locations
EXTERIOR 2nd Top coat		*Acrylic high build shield coating	*Acrylic high build shield coating	*Acrylic high build shield coating	*Acrylic high build shield coating	
INTERIOR 1st Top coat		**High quality washable acrylic top coat	**High quality washable acrylic top coat	**High quality washable acrylic top coat	**High quality washable acrylic top coat	
INTERIOR 2nd Top Coat		**High quality washable acrylic top coat	**High quality washable acrylic top coat	**High quality washable acrylic top coat	**High quality washable acrylic top coat	

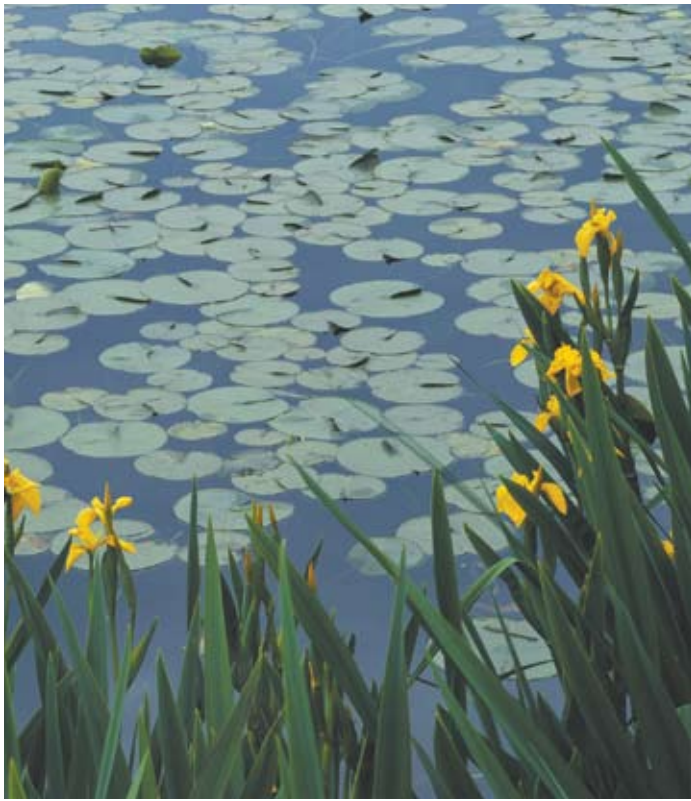

Use of Other Coatings on CSR™ Hebel® Products

In our experience with the Hebel® range of products and installation techniques, the content and attributes of the coatings that can be applied to Hebel® products can result in differing effects, durability and finishes. CSR Building Products Ltd is unable to test and verify the performance of the numerous renders and texture coatings on the market and is therefore unable to guarantee their performance over Hebel® products, other than those mentioned in this brochure.

If other coatings are preferred by our customers (other than those mentioned in this brochure), then customers must obtain their own separate warranties and guarantees from the manufacturers and distributors of other coatings and systems; confirming at very least that they will perform in accordance with and are suited to the Coating System Requirements (in Table 1) and Finish Coat Minimum Requirements (Table 2) in this Hebel® High Performance Coating Systems brochure.

Designed for future living

CSR™ Hebel® is a quality building product, and is backed by CSR™ Building Products Limited. Further details on engineering and building with Hebel® systems are available in the CSR™ Hebel® Design Guides and Technical Manual. To obtain a copy, or for further sales or technical assistance, please visit our website.

CSR™ Hebel® Website:
www.hebelaustralia.com.au

For sales enquiries or further information, please telephone us from anywhere in Australia:

1300 369 448

Hebel® PowerBase™ and Hebel® PowerFinish™ are sold through Dulux® Trade Centres Australia wide. For further sales or technical assistance please telephone Dulux® Customer service: 132 377

Hebel®

for future living

CSR™ HEBEL®
112 Wisemans Ferry Road
Somersby NSW 2250
Fax (02) 9495 7950

 CSR™ Hebel® is an exclusive licensee of Xella International GmbH.

CSR™ Hebel® is a business of CSR™ Building Products Limited ABN 55 008 631 356.

CSR™, PowerWall™, PowerPanel™, PowerFinish™, PowerBase™, HighBuild™, PowerFence™ are trademarks of CSR™ Building Products Limited. Dulux®, AcraTex® and Weathershield® are registered trademarks of Orica Australia Pty Ltd.

Guarantee

CSR™ Hebel® guarantees the products manufactured by itself and the systems described in CSR™ Hebel® literature for 7 years, subject to the terms and conditions of the CSR™ Hebel® Guarantee which can be inspected in the CSR™ Hebel® website at www.hebelaustralia.com.au. CSR™ Hebel® does not however guarantee the components, products or services, such as installation, supplied by others. CSR™ recommends that only products, components and systems recommended by it be used.

Health & Safety

Information on any known health risks of our products and how to handle them safely is on their packaging and/or the documentation accompanying them. Additional information is listed in the Material Safety Data Sheet (MSDS). To obtain a copy of a MSDS, telephone 1800 807 668 or download from www.hebelaustralia.com.au. Contractors are required by law to perform their own risk assessments before undertaking work. CSR Hebel has sample Safe Work Method Statements (SWMS) to assist in this. To obtain a sample SWMS, refer also to the above sources.

Available from:

CSR